

12R5.2

::Driver: patrick miltat ::Date: 10-11/12/2011

::Track: asmn nantes

::Event: french nats round 2

Setup sheet for Team Associated's 12R5.2

::Front Suspension

Ride height: 3,5mm

Upper arm mounts: 0° 5° 10°



Camber: 1° Toe: 0°

Droop: _____

Bumpsteer shims: 1mm

King pin lube: 30k

Springs: 0,20

Front Brace: None Soft Hard kit

Front width: _____

Roll Center

Shims on top of the steering block: full shims on top

Shims between bulkhead and caster block: _____

Notes: _____

::Front Tires

Brand & compound: jaco magenta

Diameter: 41,8mm

Wheel: jaco

Tire treatment: cs

Treatment time: 10min

Surface treated: 1/3

Notes: _____



::Rear Suspension

Ride height adjuster: _____

Chassis ride height: 4mm

Pod ride height: 4mm

Droop: 1mm

Rear width: _____

Shims under pivot: _____

Side damper

Springs: gold

Oil: 20wt

Center damper

Brand: asso

Spring: gold

Oil: 35wt

Position:

High Low



Shims: 2mm

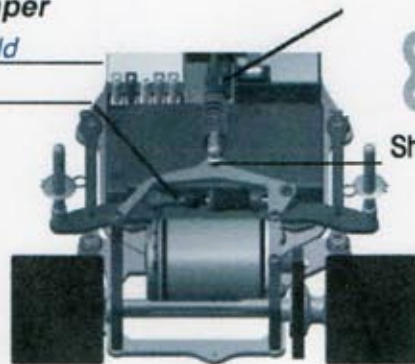

Notes: _____

::Rear Tires

Brand & compound: jaco magenta

Diameter: 43,8mm

Wheel: jaco

Tire treatment: cs

Treatment time: 45min

Surface treated: full

Notes: _____



::Body

Brand & model: black art ba04

Notes: _____

::Track Info

Composition: Asphalt Carpet

Surface: Smooth Bumpy

Traction: High Medium Low

Notes: _____

::Motor / Battery

Motor: prt 5,0 Rotor: _____

Timing: _____

Pinion: _____ Spur: 90

Rollout: 0.000

Battery: ip 6000mah

Plugs position: Front Back

::Speed Control

ESC: prt10

Setting: _____

::Transmitter

Turning Circle: _____

Steering Expo: _____

Brake E.P.: _____

Throttle Expo: _____

Notes: _____